

Special ball valves

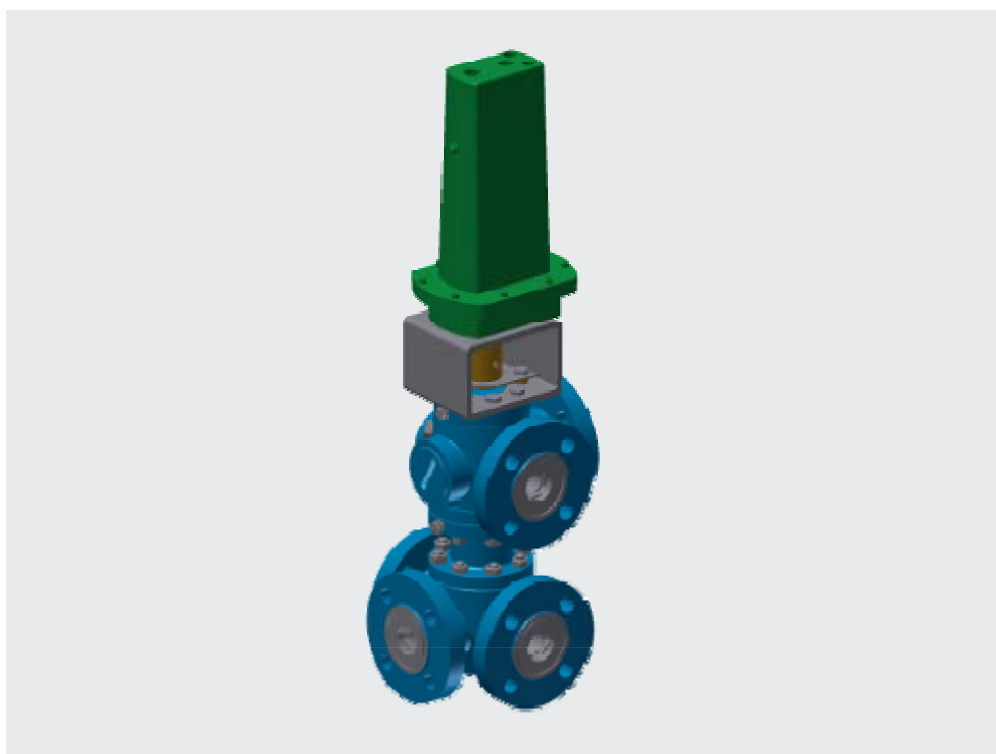

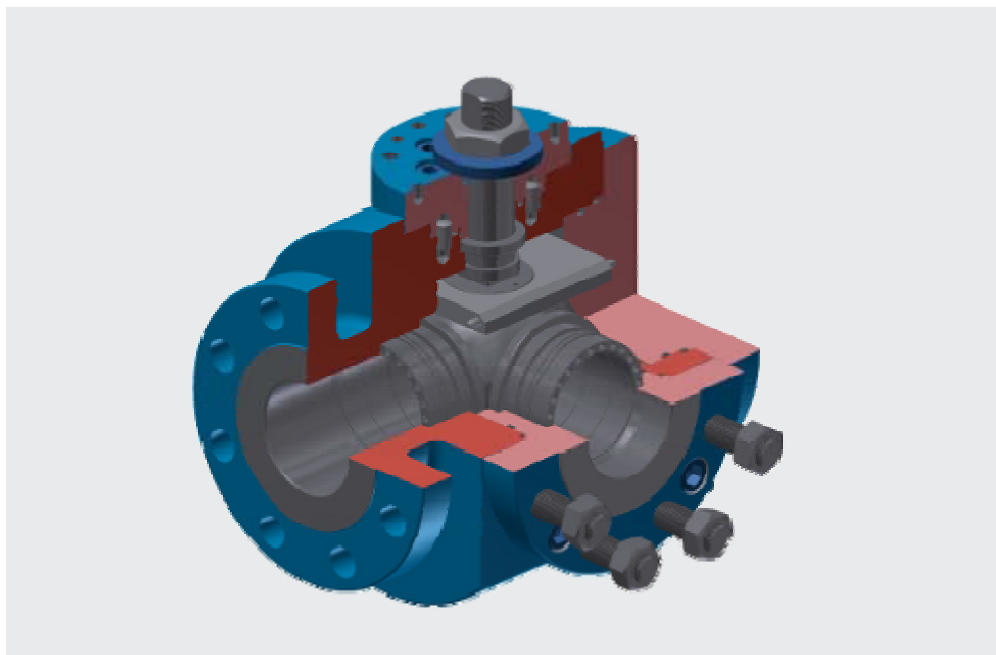
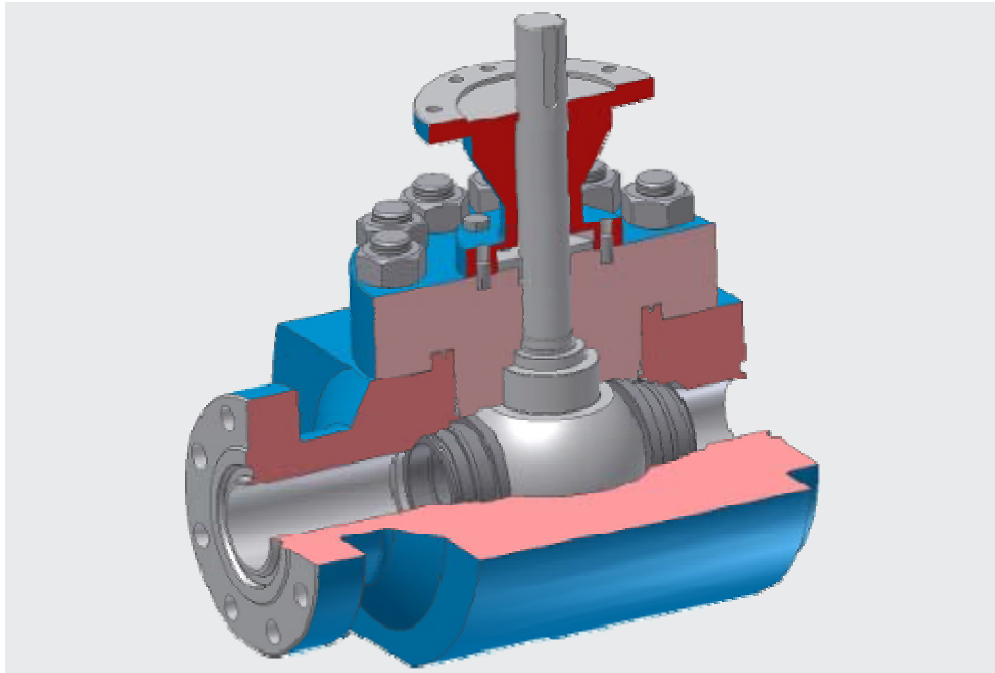

- Coupling valves with throttling option
- Shut-off ball valves with additionally integrated check valve
- "Slurry" ball valves in media with high content of coarse-grained contamination
- Tapping valves in piping
- Special shut-off valves on drilling ships
- Safety shut-off valves with response times of down to <1 s
- Valves implemented for extreme switching frequencies
- Special high-pressure valves in Top-Entry-Design
- Valves in filling plants
- Valves with special design lengths and ports
- Valves for the shut-off of measurement sections

Valves with TA-air implementation